



DESCRIPTION

**VT194P4FS**

24 V electromotive proportional actuator with electric fail safe, feedback, valve selection + flow rate setting through the screen and manual override. With screen. Max stroke 9 mm. Suitable for all axial Pettinaroli PICV (91, 92 and 93). Connection M30x1.5, adapted to Pettinaroli standards through **0A7010** (not included). Electronics fail safe is granted by 2 super capacitors.

DIMENSIONS

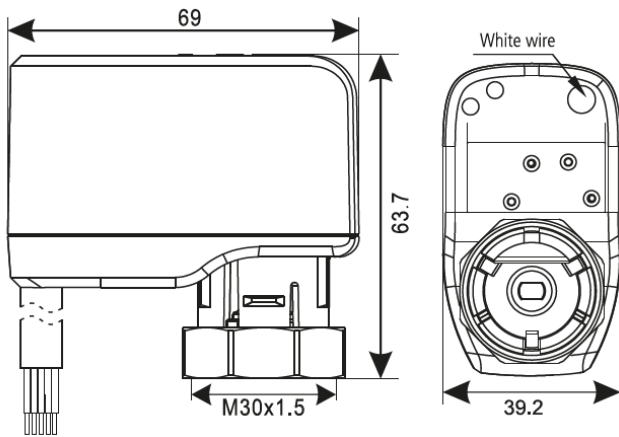

Dimensions in mm

TECHNICAL FEATURES

Type	Proportional	Running time	12 sec/mm, adjustable
Supply voltage	24V ±10% AC/DC 50-60 Hz	Max ambient temperature	-20° / + 50° C (@)
Control signal	0(2)-10VDC / 4(0)-20mA	Degree of protection	IP54
Feedback	0-10VDC / 0-20mA	Weight	140 g
Power consumption	3 W; 0.5 W in stand-by	Colour	Blue
Max starting current	1 A	Noise level	39 dB
Max stroke	9 mm – adjustable	Connection cable	4 x 0.5 mm <sup>2</sup>
Actuating force	200N	Cable length	100 cm, halogen free
		Adaptor/ring	<b>0A7010</b>

(@) non condensing

The 24 V electromotive actuator **VT194P4FS** is widely employed to drive in proportional mode pressure independent control valves PICV controlling heating and cooling systems by means of BMS (Building Management System) or suitable room thermostat (managing and generating proportional voltage and current analogue signals). Electrical connection is discussed in the following section.

APPROVALS



Pettinaroli UK - Riverside, Unit K Austin Way Hamstead Industrial Estate Birmingham B42 1DU - UK

**ELECTRICAL CONNECTION**

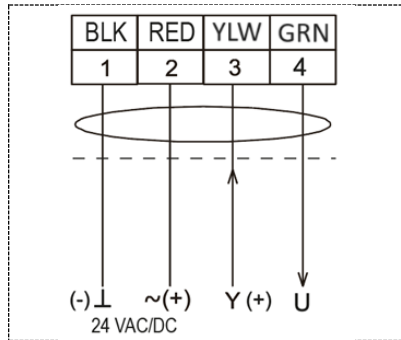

**OPERATING STATUS INDICATION**

The 24 V electromotive actuator **VT194P4FS** has a screen to set the parameters. During standard operation, it shows the control signal given to the actuator.

**BUTTONS AND FUNCTIONS**

- ☑ Power/Confirm. User could confirm the setting by one touch. Turn ON/OFF the actuator by pressing and holding.
- “+”: increase data setting
- “-”: decrease data setting

**INSTALLATION**

For electrical safety reasons the **VT194P4FS** electromotive actuator has to be installed between horizontals. Please avoid any upside down installation. Always install the actuator with the pin in fully retracted position.

Do not power the actuator if not installed on the valve.

Tighten the connecting ring by hand only.

Keep 20 cm clear over the actuator to access it, if required.

**SETTING**

The actuator detects the bottom end point every time it is powered up. After 5 seconds from powering, the actuator starts flashing “CHg” while the capacitors are charging; then, “0-10” flashes 3 times, then the initialization starts (finding the bottom end stroke): the actuator firstly moves the pin up (2) and then down.

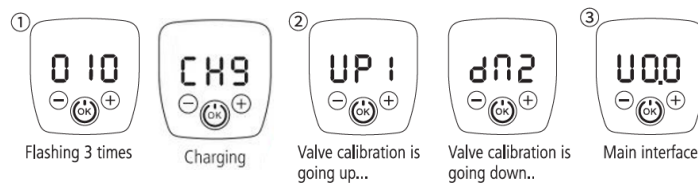

If a power shortage occurs during this phase, initialisation will be aborted and the actuator switches to fail safe mode.

The actuator stores the settings: in order to correctly store the settings, please do not power off the actuator for 10 seconds.

**VALVE SELECTION AND MAX FLOW RATE SETTING**

Presetting of the PICV 92, 91 and 93 series and control valve 662, 663, 664 can be done by selecting the valve model and the desired design flow rate. The actuator will store the stroke corresponding to the selected valve and flow rate.

1. Press and hold “+” and “OK” for 3 sec at least to enter the valve selection menu. “NON” will firstly show: this means that no valve model is selected and the stroke can be manually entered.
2. Press “+” or “-” to change the valve model. Selectable valve models are:

- 15V: 92VL DN15
- 15L: 92L DN15
- 15H: 92H DN15
- 20L: 92L DN20
- 20H: 92H DN20
- 25L: 92L DN25
- 25H: 92H DN25
- 32H: 92H DN32
- 40H: 92H DN40
- 50H: 92H DN50

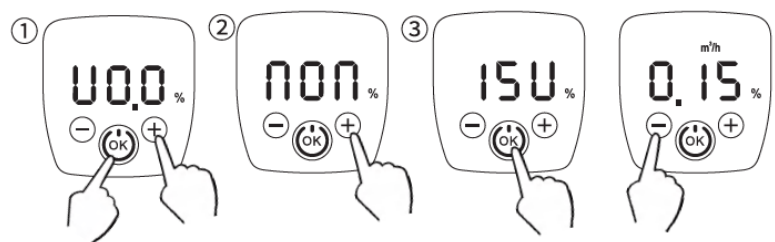

Used on PICV 91 series and control valves 662, 663, 664, select 15V and keep maximum flow rate  
 Used on PICV 93 series, select 25L and keep maximum flow rate

3. Press OK to confirm the selected valve model and proceed to max flow rate setting. By default, anytime the user browses the valve model selection menu and select a valve model, the corresponding max flow rate is shown:

VALVE MODEL	MAX FLOW [GPM]	MAX FLOW [m3/h]
15V	0.65	0.15
15L	1.98	0.45
15H	3.74	0.85
20L	4.40	1.00
20H	8.15	1.85

VALVE MODEL	MAX FLOW [GPM]	MAX FLOW [m3/h]
25L	11.00	2.50
25H	14.50	3.30
32H	22.90	5.20
40H	39.60	9.00
50H	61.50	14.00

4. Press “+” or “-” to change the max flow rate, then press “OK” to confirm and go back to the main interface.

STROKE VERIFICATION

1. Press and hold “-” for 3 sec at least; all LED indicators will flash.
2. The current stroke setting is shown. Buttons “-” and “+” are not active.
3. Press OK to confirm the setting and return to main interface or wait 5 seconds.

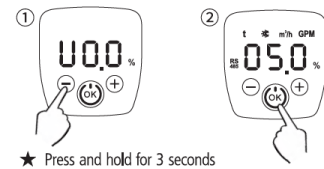

STROKE SETTING (whenever a valve is not selected, so “NON” is shown up)

4. Press and hold “-” for 3 sec at least to enter the stroke setting, all LED indicators will flash.
5. Press “+” or “-” to change the stroke, the adjustable range is 2-9 mm.
6. Press OK to confirm the setting and return to main interface.

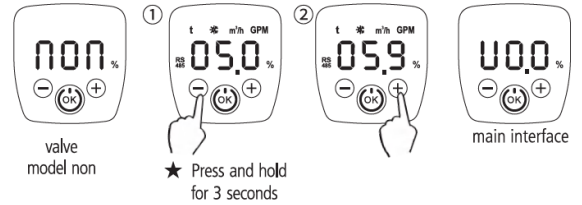

MANUAL OVERRIDE (in manual override mode, the fail safe does not operate)

1. From the main interface, short press “OK” to enter the manual override. The current opening percentage is shown (according to the selected control characteristics).
2. Press “+” or “-” to change the opening percentage of the actuator, between 0% (fully closed) and 100% (fully open). AVOID to press “OK” to keep the actuator in manual override mode.
3. If “OK” button is pressed, the actuator exits the manual override mode.

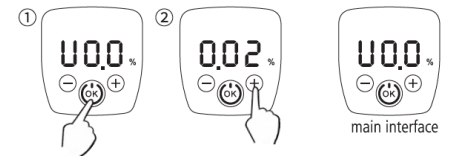

CONTROL SIGNAL SELECTION

1. Press and hold “OK” and “-” for 3 sec at least to enter the control signal selection. The current control signal will flash.
2. Press “+” or “-” to select the control signal.
  - a. 010: 0-10V control signal (default).
  - b. 210: 2-10V control signal.
  - c. 420: 4-20mA control signal.
  - d. 020: 0-20mA control signal.
3. Press OK to confirm the setting and return to main interface. The feedback signal is given as voltage signal in case 0-10V and 2-10V are selected; It is given as current in case 4-20mA and 0-20mA are selected.

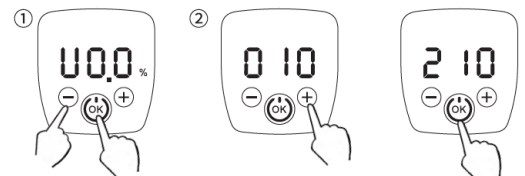

**MENU SETTINGS:** to enter the menu settings, press and hold “+” and “-” for 3 sec at least. Three settings can be selected defined: *running speed, unit of measure, control characteristics.*

I. RUNNING SPEED SETTING

1. Press and hold “+” and “-” for 3 sec at least to enter the running speed setting. “t” will flash.
2. Press “+” or “-” to change the running time. It can be set between 5 s/mm up to 20 s/mm. Default setting is 12 s/mm.
3. Press OK to confirm the setting and return to main interface or press and hold “+” and “-” again to enter the following parameter.

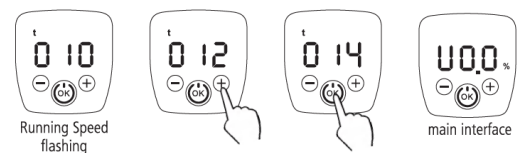

II. UNIT OF MEASURE SETTING

1. Press and hold “+” and “-” until the selected units of measure start flashing. Flow rate and temperature units can be selected between metric or imperial:
  - m<sup>3</sup>/h and °C – metric (default);
  - GPM and °F – imperial;
2. Press “+” or “-” to change the units.
3. Press OK to confirm the setting and return to main interface or press and hold “+” and “-” again to enter the following parameter.

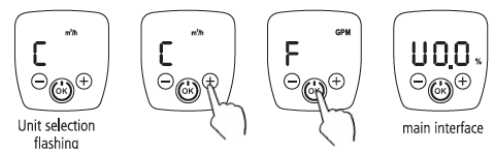

III. CONTROL CHARACTERISTICS

1. Press and hold “+” and “-” until the control characteristics options start flashing:  
Linear – LIN;  
Shallow Equalpercentage – LQU;  
Equalpercentage – EQU (default);
2. Press “+” or “-” to change the control characteristics.
3. Press OK to confirm the setting and return to main interface.

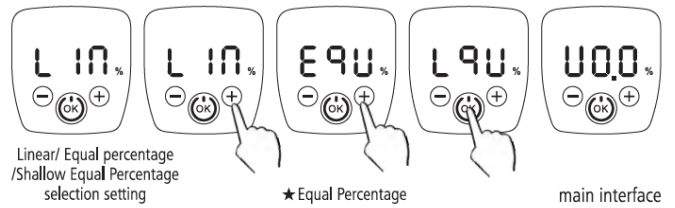

IV. FAIL SAFE DIRECTION

1. Press and hold “+” and “-” until the control characteristics options start flashing:  
Closing – CLO (default);  
Opening – OPE;
2. Press “+” or “-” to change the control characteristics.
3. Press OK to confirm the setting and return to main interface.

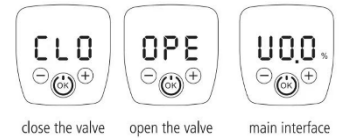

As soon as the power is cut off, the fail safe operation starts. The screen will start displaying “POF”. In order to ease the removal of the actuator (in case of maintenance) from the valve and its further re-installation (when the power is cut off), Pettinaroli suggests to set the fail safe direction temporarily on Opening – “OPE”, so that the shutter is fully retracted. After that, in case the wished fail safe direction is Closing - “CLO”, the user has to set the parameter back to Closing – “CLO”.

FAIL SAFE OPERATION

Any time the power is cut off, irrespective of the control signal received by the actuator, the actuator moves to the fail safe position set in the menu. During the capacitors discharging, the indication “POF” will be displayed. Once the capacitors are fully discharged, the screen goes off.



Safe unmounting

Whenever the actuator had to be switched off and removed from the valve, safe unmounting procedure has to be followed. This allows to mount again the actuator on the valve easily and safely. It stops the operation of fail-safe.

1. Short press “OK” to enter the manual override when POF is shown; it works the same if manual override has been enter also before switching the actuator off. The current opening percentage is shown (according to the selected control characteristics).
2. Press “+” or “-” to change the opening percentage of the actuator, between 0% (fully closed) and 100% (fully open). AVOID to press “OK” to keep the actuator in manual override mode.
3. Keep this mode until the capacitors are fully discharged. The user can meanwhile remove the actuator.
4. If “OK” button is pressed, the actuator exits the manual override mode, POF is shown and it is driven to selected fail safe position.



RESTORE FACTORY SETTING

1. Press and hold “OK” for 5 sec. “RES” will flash.
2. Press again “OK”: the screen will show alternately RES and OK; then the factory reset is completed. If the user does not press “OK”, the factory setting will be aborted after 10 sec.

