



DESCRIPTION

701CN

Water meter union connection. With gasket

DIMENSIONS

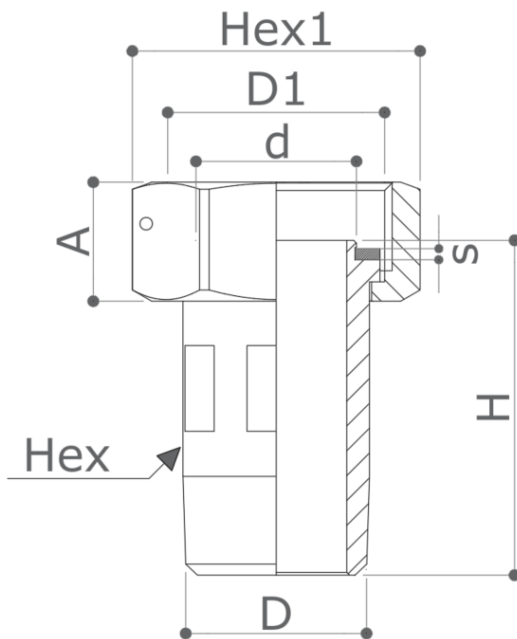

| | |
|-------------------|------|
| D | ½" |
| D1 | ¾" |
| A | 13.5 |
| H | 39.5 |
| Hex | 19 |
| Hex1 | 30 |
| d | 16.5 |
| s | 2 |
| Weight [g] | 90 |

Dimensions in mm

All threads are conformed to EN 10226-1 standard

MATERIALS

Nut CW617N (EN 12165) CuZn40Pb2

Union CW617N (EN 12165) CuZn40Pb2

Gasket NBR

RECOMMENDED WORKING TEMPERATURE/PRESSURE LIMIT

10 bar – 90°C – non shock