

DESCRIPTION

# VT194DT5



24 V electromotive proportional actuator with two NTS1001 digital temperature sensors for DeltaT control, valve selection + flow rate setting through the screen and manual override. The actuator can also control based on Return temperature only. With screen. Max stroke 9 mm. Suitable for all axial Pettinaroli PICV (**91**, **92** and **93**). Connection M30x1.5, adapted to Pettinaroli standards through 0A7010 (not included).

Depending on the control mode, the actuator can:

- Work with a DeltaT manager algorithm, allowing a proportional 0-10 VDC (only) input from the controller and parallelly maintaining the set DeltaT every time it is below the target. Suitable for heating and cooling.
- Work with Return Temperature manager algorithm, allowing a proportional 0-10V input from the controller and parallelly maintaining the set Return Temperature every time it is below/over the target. Suitable for heating and cooling.
- Work as a standard proportional actuator, allowing 0(2)-10 VDC and 4(0)-20 mA control signal.

DIMENSIONS

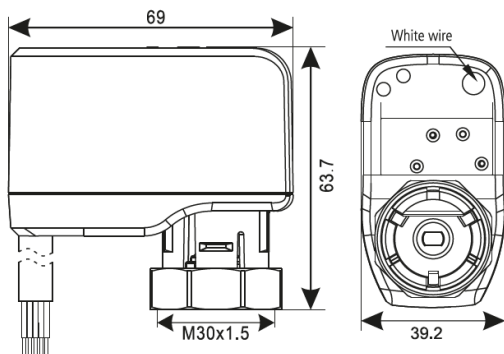

Dimensions in mm

TECHNICAL FEATURES

Type	Proportional and DeltaT control	Degree of protection	IP54
Supply voltage	24V ±10% AC/DC 50-60 Hz	Communication protocol	ModBus RTU
Control signal	0(2)-10VDC / 4(0)-20mA	Weight	250 g
Temperature sensor	2 x NTS1001	Colour	Blue
Accuracy T sensors	±0.2°C (25-45°C) - ±0.5°C (-20-+85°C) Max	Noise level	39 dB
Power consumption	2 W (0.5W Stand-by)	Connection cable	5 x 0.5 mm <sup>2</sup>
Max starting current	1 A	Supply T cable (white) length	150 cm – T1
Max stroke	9 mm – adjustable	Return T cable (black) length	100 cm – T2
Actuating force	200N	Cable length (with halogen)	55 cm
Running time	12 sec/mm, adjustable	Adaptor/ring	<b>0A7010</b>
Max ambient temperature (@) non condensing	-20° / + 50° C (@)		

The 24 V electromotive actuator **VT194DT5** is turn-key technology: it is widely employed to drive pressure independent control valves PICV in heating and cooling systems by means of BMS (Building Management System) or suitable room thermostat (managing and generating proportional voltage and current analogue signals) combining proportional signal and DeltaT/ReturnT management: this way, it ensures that the DeltaT across the terminal unit is always achieved. Electrical connection is discussed in the following section.

APPROVALS



Pettinaroli UK - Riverside, Unit K Austin Way Hamstead Industrial Estate Birmingham B42 1DU – UK

**ELECTRICAL CONNECTION**

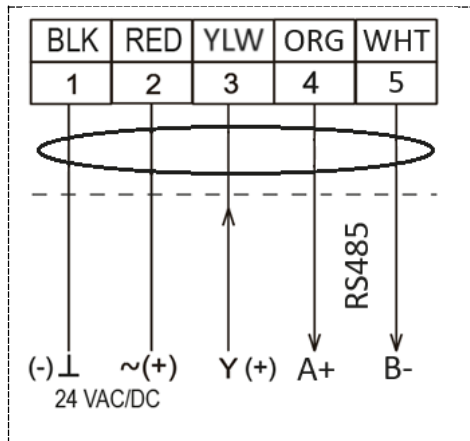

**OPERATING STATUS INDICATION**

The 24 V electromotive actuator **VT194DT5** has a screen to set the parameters. During standard operation, it shows Supply and return temperatures and the opening percentage of the valve.

**BUTTONS AND FUNCTIONS**

- ☺ Power/Confirm. User could confirm the setting by one touch. Turn ON/OFF the actuator by pressing and holding.
- “+”: increase data setting
- “-”: decrease data setting

**MODBUS RTU**

The actuator has an inbuilt ModBus RTU communication with RS485. Please refer to the wiring diagram beside for the electrical connection. 120 Ohm termination resistor has to be install. The user has to make sure that all the devices connected to the same ModBus chain as the same Common.

General RS485 default settings:

- RS485 Baud rate: 19200 (default) – adjustable;
- RS485 Parity Check bit: No Parity – adjustable;
- RS485 Stop bit: 1 stop bit – adjustable;

Please refer to the instruction manual for detailed information on ModBus parameters and coding.

**TEMPERATURE SENSORS**

Each actuator has 2 NTS1001 digital temperature sensors already installed and calibrated. The drawing beside shows dimensions of the sensor and sensor holder.

They are suitable for installation directly in contact with treated water of HVAC systems.

They can fit Pettinaroli temperature sensors fittings and valves with PN25 rating:

- Tee connection 35S+8090;
- 35TS;
- 52CES;
- OEMTS (up tot 1”);

In order to install the sensors on DN40 and DN50 pipes, thermowell 0VTPS is required; Installation procedure:

1. the sensor has to be inserted till the bottom of the thermo-wells, by unscrewing the screw of brass probe holder;
2. the holder as to be screwed in the M10 connection of 0VTPS;
3. the screw of probe holder has to be tightened to hold the sensor.

The sensors are provided with an O-Ring each.

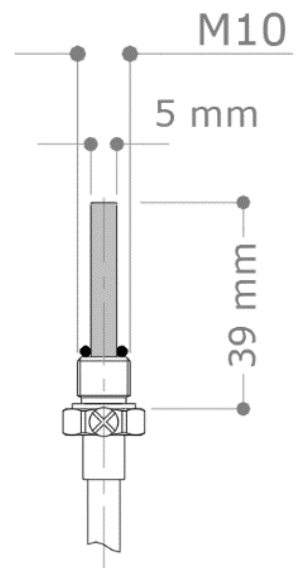

**INSTALLATION**

For electrical safety reasons the **VT194DT5** electromotive actuator has to be installed between horizontals. Please avoid any upside down installation. Always install the actuator with the pin in fully retracted position.

Do not power the actuator if not installed on the valve.

Tighten the connecting ring by hand only.

Keep 20 cm clear over the actuator to access it, if required.

**SETTING**

The actuator detects the bottom end point every time it is powered up. After powering the first time, “2 t” flashes 3 times, then the initialization starts (finding the bottom end stroke): the actuator firstly moves the pin up (2) and then down.

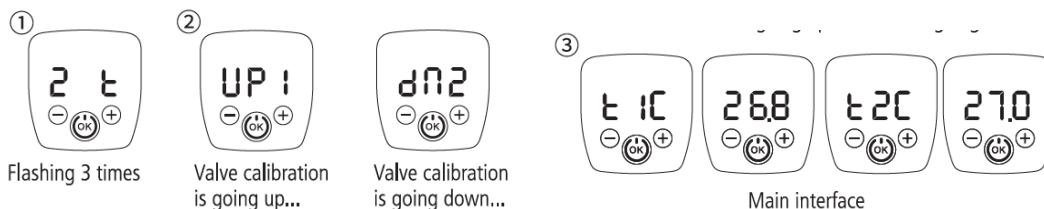

The actuator stores the settings: in order to correctly store the settings, please do not power off the actuator for 10 seconds.

**VALVE SELECTION AND MAX FLOW RATE SETTING**

Presetting of the PICV 92, 91 and 93 series and control valve 662, 663, 664 can be done by selecting the valve model and the desired design flow rate. The actuator will store the stroke corresponding to the selected valve and flow rate.

1. Press and hold “+” and “OK” for 3 sec at least to enter the valve selection menu. “NON” will be firstly shown: this means that no valve model is selected and the stroke can be manually entered. Default stroke is 3.2 mm.
2. Press “+” or “-” to change the valve model. Selectable valve models are:

- 15V: 92VL DN15
- 15L: 92L DN15
- 15H: 92H DN15
- 20L: 92L DN20
- 20H: 92H DN20
- 25L: 92L DN25
- 25H: 92H DN25
- 32H: 92H DN32
- 40H: 92H DN40
- 50H: 92H DN50

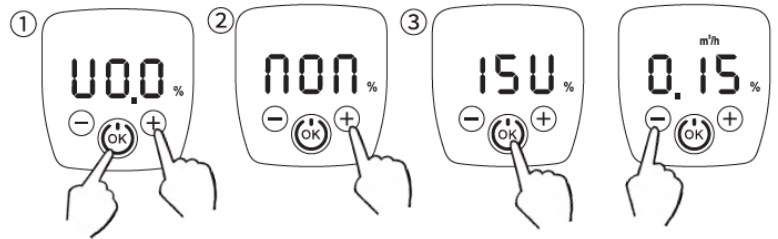

Used on PICV 91 series and control valves 662, 663, 664, select 15V and keep maximum flow rate  
 Used on PICV 93 series, select 25L and keep maximum flow rate

3. Press OK to confirm the selected valve model and proceed to max flow rate setting. By default, anytime the user browses the valve model selection menu and select a valve model, the corresponding max flow rate is shown:

VALVE MODEL	MAX FLOW [GPM]	MAX FLOW [m3/h]
15V	0.65	0.15
15L	1.98	0.45
15H	3.74	0.85
20L	4.40	1.00
20H	8.15	1.85

VALVE MODEL	MAX FLOW [GPM]	MAX FLOW [m3/h]
25L	11.00	2.50
25H	14.50	3.30
32H	22.90	5.20
40H	39.60	9.00
50H	61.50	14.00

4. Press “+” or “-” to change the max flow rate, then press “OK” to confirm and go back to the main interface.

**STROKE VERIFICATION**

1. Press and hold “-” for 3 sec at least; all LED indicators will flash.
2. The current stroke setting is shown. Buttons “-” and “+” are not active.
3. Press OK to confirm the setting and return to main interface or wait 5 seconds.

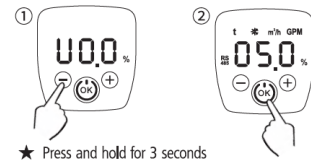

**STROKE SETTING (whenever a valve is not selected, so “NON” is shown up)**

1. Press and hold “-” for 3 sec at least to enter the stroke setting, all LED indicators will flash.
2. Press “+” or “-” to change the stroke, the adjustable range is 1-9 mm.
3. Press OK to confirm the setting and return to main interface.

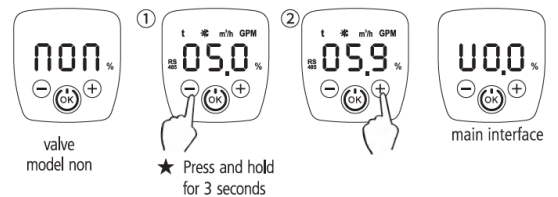

**MANUAL OVERRIDE**

1. From the main interface, short press “OK” to enter the manual override. The current opening percentage is shown (according to the selected control characteristics).
2. Press “+” or “-” to change the opening percentage of the actuator, between 0% (fully closed) and 100% (fully open). **AVOID to press “OK” to keep the actuator in manual override mode.**
3. If “OK” button is pressed, the actuator exits the manual override mode.



**CONTROL MODE SELECTION**

1. Press and hold "OK" and "-" for 3 sec at least to enter the control signal selection. The current control signal will flash.
2. Press "+" or "-" to select the control signal.

- 2 t: DeltaT mode; it allows 0-10VDC signal and DeltaT (default).
- 1 t: ReturnT mode; it allows 0-10VDC signal and ReturnT control.
- 010: 0-10V control signal.
- 210: 2-10V control signal.
- 420: 4-20mA control signal.
- 020: 0-20mA control signal.

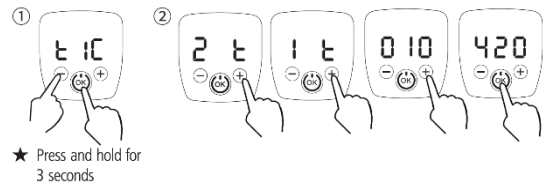

3. Press OK to confirm the setting and return to main interface.

**MENU SETTINGS:** to enter the menu settings, press and hold "+" and "-" for 3 sec at least. Following settings can be defined: *ModBus Address, running speed, heating cooling mode, Temperature setting, unit of measure, control characteristics.*

**I. MODBUS RTU ADDRESS**

1. Press and hold "+" and "-" for 3 sec at least to enter the Modbus RTU address setting. "RS485" will flash.
2. Press "+" or "-" to change the address. Default setting is 001. Max selectable address is 247. The maximum number of connected devices can be limited by communication distance and environmental interferences
3. Press OK to confirm the setting and return to main interface or press and hold "+" and "-" again to enter the following parameter.

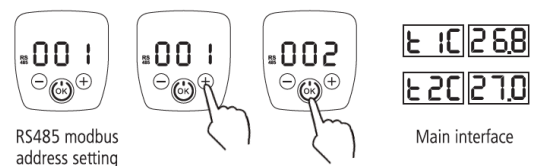

**II. RUNNING SPEED SETTING**

1. Press and hold "+" and "-" for 3 sec at least to enter the running speed setting. "t" will flash.
2. Press "+" or "-" to change the running time. It can be set between 5 s/mm up to 20 s/mm. **Default setting is 12 s/mm.**
3. Press OK to confirm the setting and return to main interface or press and hold "+" and "-" again to enter the following parameter.

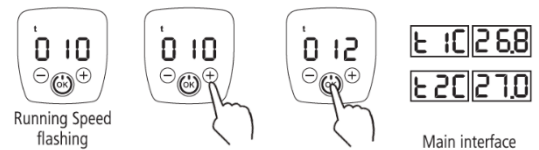

**III. HEATING / COOLING MODE**

1. Press and hold "+" and "-" until the heating/cooling LED starts flashing. Indication of heating or cooling start flashing too. **COL – Cooling (default);**  
HOT – Heating;
2. Press "+" or "-" to change the mode.
3. Press OK to confirm the setting and return to main interface or press and hold "+" and "-" again to enter the following parameter.

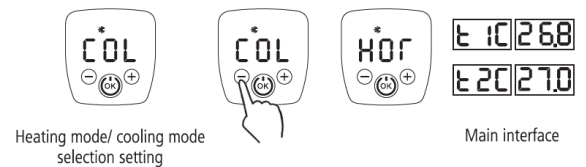

**IV. DeltaT TEMPERATURE SETTING (if "2 t" mode is selected)**

1. Press and hold "+" and "-" until the DeltaT value starts flashing. The temperature is shown in the selected unit of measure (see the following setting). The selectable range is 1-30°C. Precision: 0.1°C
2. Press "+" or "-" to change the DeltaT set point. **Default setting: 9°C**
3. Press OK to confirm the setting and return to main interface or press and hold "+" and "-" again to enter the following parameter.

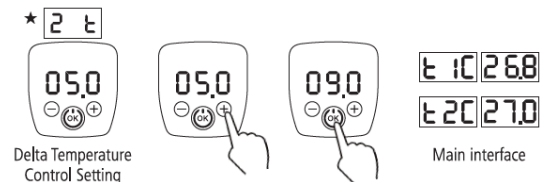

**V. RETURN TEMPERATURE SETTING (if "1 t" mode is selected)**

1. Press and hold "+" and "-" until the Return Temperature value starts flashing. The temperature is shown in the selected unit of measure (see the following setting). The selectable range is 1-90°C. Default ReturnT sensor is T2 (black wire). Precision: 0.1°C
2. Press "+" or "-" to change the Return T set point. **Default setting: 13.5°C**
3. Press OK to confirm the setting and return to main interface or press and hold "+" and "-" again to enter the following parameter.

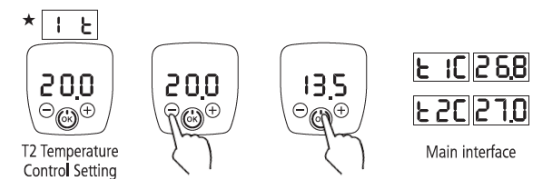

VI. UNIT OF MEASURE SETTING

1. Press and hold “+” and “-” until the selected units of measure start flashing. Flow rate and temperature units can be selected between metric or imperial:  
**m<sup>3</sup>/h and °C – metric (default);**  
 GPM and °F – imperial;
2. Press “+” or “-” to change the units.
3. Press OK to confirm the setting and return to main interface or press and hold “+” and “-” again to enter the following parameter.

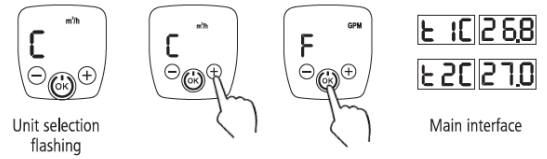

VII. CONTROL CHARACTERISTICS

1. Press and hold “+” and “-” until the control characteristics options start flashing:  
 Linear – LIN;  
 Shallow Equalpercentage – LQU;  
**Equalpercentage – EQU (default);**  
 Shallow Equalpercentage;
2. Press “+” or “-” to change the control characteristics.
3. Press OK to confirm the setting and return to main interface.

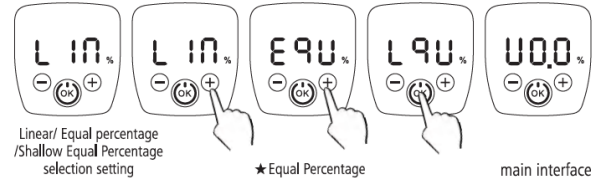

RESTORE FACTORY SETTING

1. Press and hold “OK” for 5 sec. “RES” will flash.
2. Press again “OK”: the screen will show alternately RES and OK; then the factory reset is completed. If the user does not press “OK”, the factory setting will be aborted after 10 sec.

