

DESCRIPTION

# P100/1

Press x F full passage ballvalve made by non dezincifiable alloy. T.E.A. Plus.  
Reversible green steel lever.

Conform to **EN 13828** and **EN 1254/7** standards



DIMENSIONS

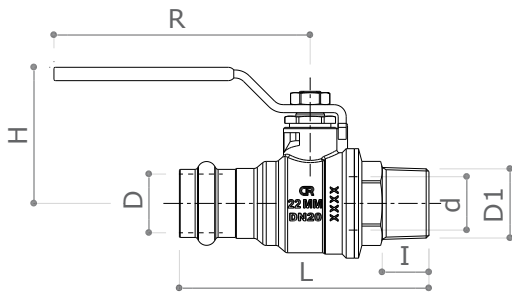

D	15	18	22	28	35	42	54
D1	1/2"	3/4"	3/4"	1"	1 1/4"	1 1/2"	2"
d	15	15	20	25	32	40	50
L	83	85	94	107	116	133	163
H	39	40	50	63	68	84	92
I	15	15	15	19	20	20	24,5
R	75	75	95	120	120	150	150
Pressing profile	M and V	M and V	M and V	M and V	M and V	V*	V*
Weight [g]	214	232	351	596	901	1367	2086

Dimensions in mm

MATERIALS

- Body** CW511L (UNI EN 12165) CuZn38As T.E.A. Plus
- Ball** CW617N (UNI EN 12165) CuZn40Pb2 T.E.A. Plus
- Stem** CW602N (UNI EN 12164) CuZn36Pb2
- Stuffing box** CW614N (UNI EN 12164) CuZn39Pb3
- Seats** 2 x PTFE + 1 x PTFE on the stem
- O-Rings** 2 x FKM stem + 2 x EPDM end connections
- Handle** Steel with Delta Protect treatment. PVC coating applied using "Pad printing" technique.

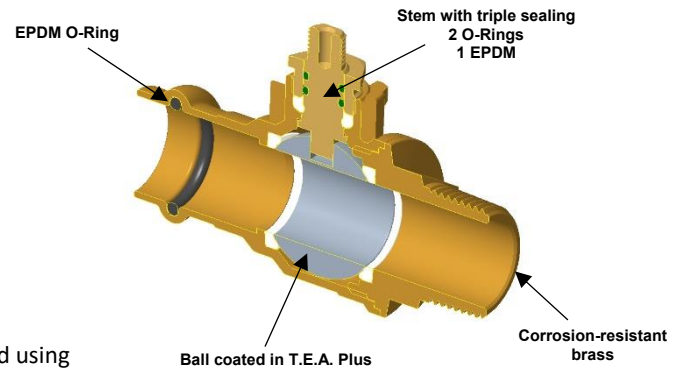

RECOMMENDED WORKING TEMPERATURE/PRESSURE LIMITS

- 16 bar – 30°C – non shock
- 10 bar – 95°C – non shock
- 20°C: lower temperature limit with 50% glycol. No frost.

CERTIFICATIONS

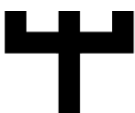

PRESSURE DROP DIAGRAM

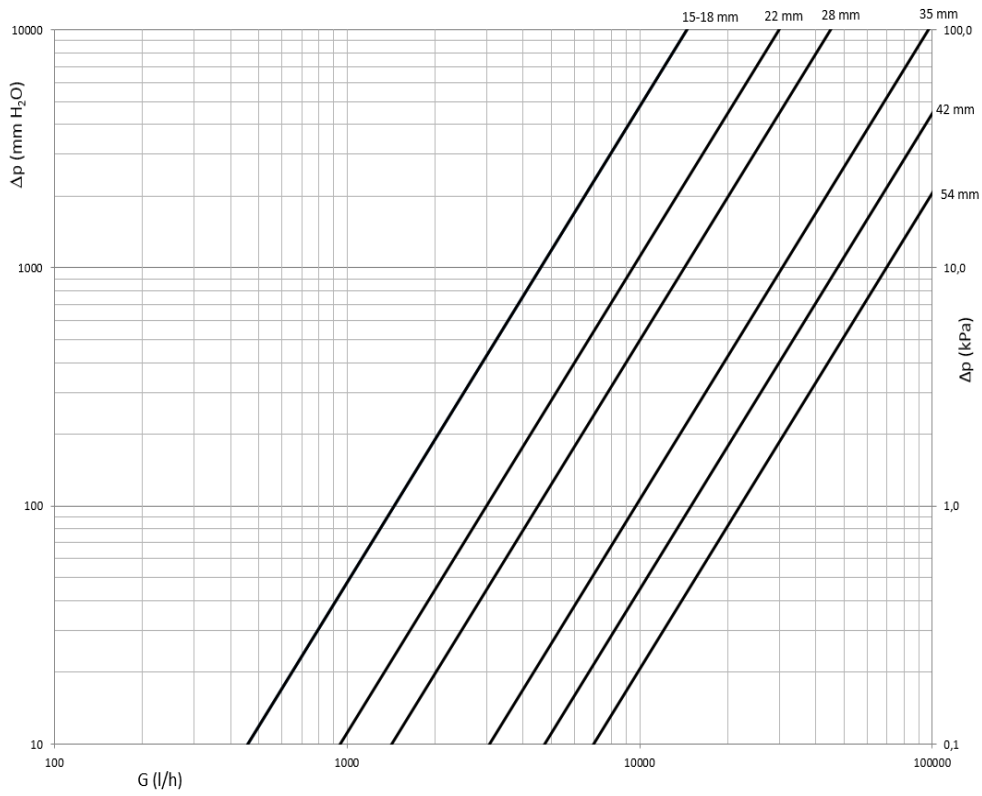

Dim.	15	18	22	28
Kv	14.5	14.5	30	45
PN	16	16	16	16

PRESSURE/TEMPERATURE DIAGRAM

