



DESCRIPTION

EM603

Ultrasonic thermal energy meter for heating and cooling applications certified according to MID directive (Measurement Instruments Directive 2014/32/EU). Composed by:

- **An ultrasonic flow meter (flow sensor):** it allows to measure with high accuracy and reliability the flow rate circulating through the device. Available in the threaded version (from 3/4" to 2") or in the flanged one (from DN50 to DN300);
- **An electronic display unit (calculator):** it allows to set a series of characteristic parameters of the device and view and consult the data logs saved by the instrument. It houses part of the working and calculating electronic of the device, including the communication module and the power supply module. It can be positioned only on the wall by using the dedicated support included with the product;
- **An electronic protection box (electronic box):** it allows to protect the flow sensor working electronics from any thermal shocks due to the operation of the system (overheating of the flow sensor or condensation formation). Based on the size of the meter considered, available in the die-cast version, integral with the connection cable, or in the robust version, installed on the flow sensor and equipped with a specific display;
- **A set of PT500 temperature probes:** they allow to measure the temperature differential between flow and return and thus determine the thermal energy consumption. Available in the direct immersion version or in the pocket version (pockets for inserting the probes included with the product).

Based on the requirements, the device can be equipped with one or two different communication protocols selectable between **M-bus**, **M-bus Wireless**, **Modbus RTU**, **Modbus TCP/IP**, **BACnet® MS/TP**, **BACnet® IP** or **LoRaWan** and with **integrated battery** power supply (16 years lifetime) or **24V AC/DC** or **230V AC** external power supply. The availability of a given type of power supply may vary depending on the type of protocol selected. Equipped with an optical interface for local reading and additional pulse inputs for connecting other measuring devices such as drinking water meters (two inputs per selected protocol).

SIZES AND SELECTION

The size of the meter is distinguished by the nominal flow rate of the device q_p . In addition to this value, each meter is characterized by three other characteristic flow rate values q_c , q_i and q_s (cut-off flow rate, minimum flow rate and maximum flow rate respectively). Once the design flow rate q has been defined, the most suitable size of meter must be selected in such a way that this value is between the minimum and the nominal one ($q_i < q < q_p$). The different available sizes of EM603 thermal energy meter with their respective characteristic flow values are collected in the following table:

Article*	Flow rate				Dynamic range	Flow sensor length	Flow sensor connection**
	Cut-off q_c [l/h]	Minimum q_i [l/h]	Nominal q_p [m³/h]	Maximum q_s [m³/h]			
EM603	3	15	1,5	3	100:1	110 mm	3/4"
EM603	5	25	2,5	5	100:1	130 mm	1"
EM603	7	35	3,5	7	100:1	260 mm	1 1/4"
EM603	12	60	6	12	100:1	260 mm	1 1/4"
EM603	20	100	10	20	100:1	300 mm	2"
EM603	30	150	15	30	100:1	270 mm	DN50
EM603	50	250	25	50	100:1	300 mm	DN65
EM603	80	400	40	80	100:1	300 mm	DN80
EM603	120	600	60	120	100:1	360 mm	DN100
EM603	200	1000	100	200	100:1	360 mm	DN125
EM603	500	2500	250	500	100:1	500 mm	DN150
EM603	800	4000	400	800	100:1	500 mm	DN200
EM603	1200	6000	600	1200	100:1	600 mm	DN250
EM603	2000	10000	1000	2000	100:1	500 mm	DN300

*As standard, for models with a nominal flow rate of up to 6 m³/h, the temperature probes are of the direct immersion type. For the 10 m³/h models and above, however, they are of the pocket type. **Threaded models: thread according to EN ISO 228-1. – Flanged models: type B flange with raised face according to EN 1092-1.

DIMENSIONS

The characteristic dimensions of the different elements making up the EM603 thermal energy meter are shown below (unit of measurement mm):

CALCULATOR

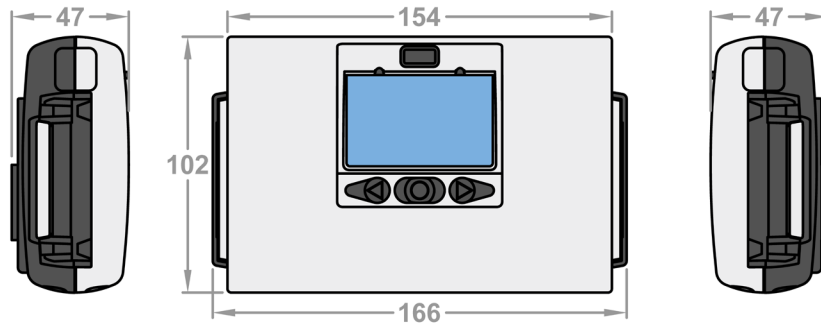

FLOW SENSOR: 3/4" → 1"

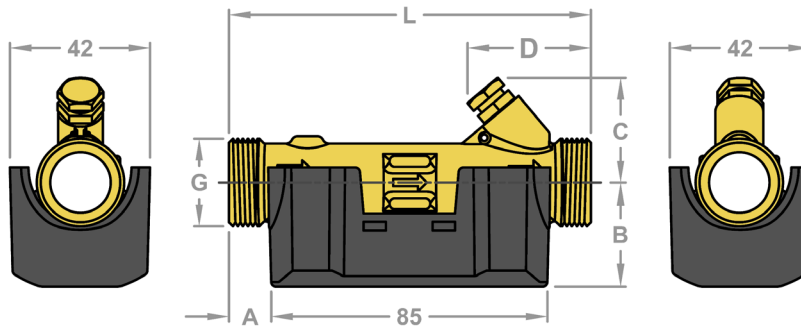

Article	Size	G**	L	A	B	C	D	Weight [g]*
EM603	1,5 m ³ /h	3/4"	110	12	35	32	38	~700
EM603	2,5 m ³ /h	1"	130	52	38	38	78	~1000

*The weight indicated includes the electronic box and the related connection cable. **Thread according to EN ISO 228-1.

FLOW SENSOR: 1 1/4" → 2"

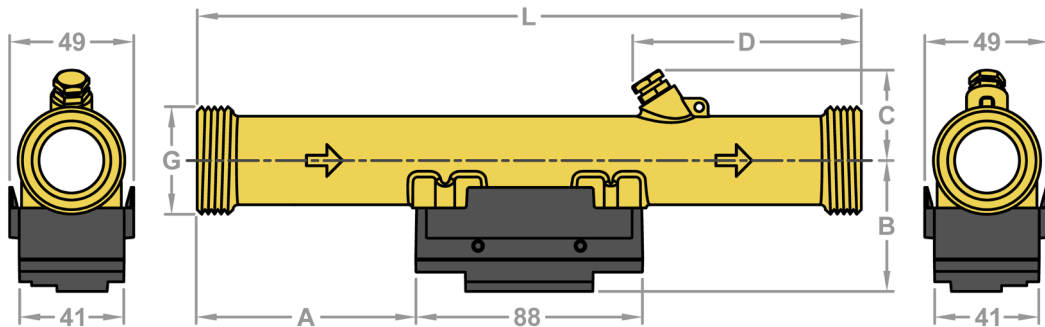

Article	Size	G**	L	A	B	C	D	Weight [g]*
EM603	3,5 m ³ /h	1 1/4"	260	81	51	35	89	~1900
EM603	6 m ³ /h	1 1/4"	260	81	51	35	89	~1900
EM603	10 m ³ /h	2"	300	106	55	39	94	~2900

*The weight indicated includes the electronic box and the related connection cable. ** Thread according to EN ISO 228-1.

DIMENSIONS

The characteristic dimensions of the different elements making up the EM603 thermal energy meter are shown below (unit of measurement mm):

FLOW SENSOR: DN65 → DN125

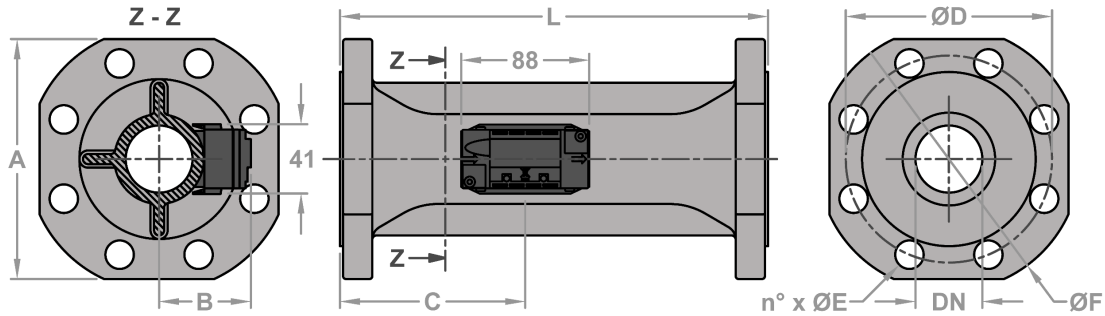

Article	Size	DN**	L	A	B	C	ØD	n° x ØE	ØF	Weight [kg]*
EM603	10 m ³ /h	50	270	145	58	115	125	4 x 18	165	~13,5
EM603	20 m ³ /h	65	300	168	65	130	145	8 x 18	185	~13,5
EM603	40 m ³ /h	80	300	184	75	130	160	8 x 18	200	~17,1
EM603	60 m ³ /h	100	360	220	92	148	190	8 x 22	235	~22
EM603	100 m ³ /h	125	350	255	92	138	220	8 x 26	270	~28,5

*The weight indicated includes the electronic box and the related connection cable. **Type B flange with raised face according to EN 1092-1.

ELECTRONIC BOX: 3/4" → DN125

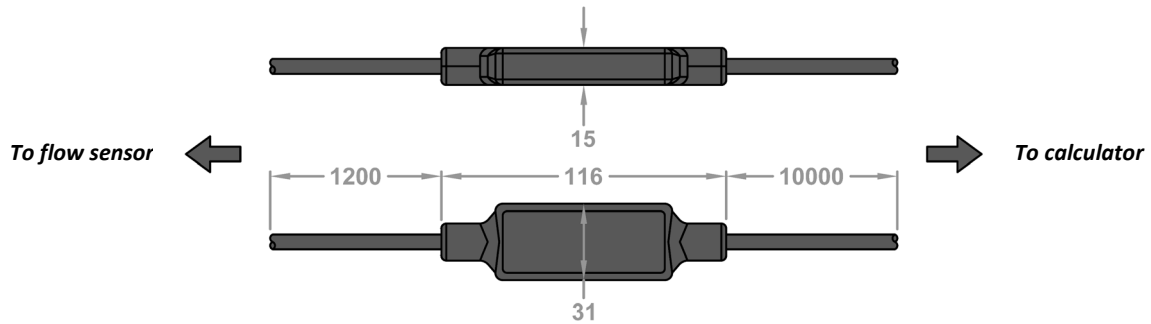

FLOW SENSOR AND ELECTRONIC BOX: DN150 → DN300

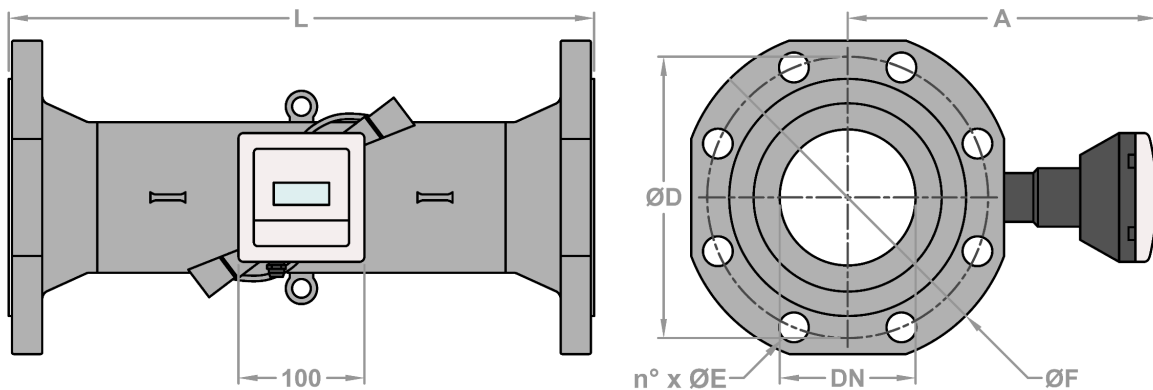

Article	Size	DN**	L	A	ØD	n° x ØE	ØF	Weight [kg]*
EM603	250 m ³ /h	150	500	264	250	8 x 26	300	~33
EM603	400 m ³ /h	200	500	281	310	12 x 26	360	~53
EM603	600 m ³ /h	250	600	341	370	12 x 30	425	~83
EM603	1000 m ³ /h	300	500	370	410	12 x 26	460	~80

*The weight indicated includes the electronic box and the related connection cable. **Type B flange with raised face according to EN 1092-1.

DIMENSIONS

The characteristic dimensions of the different elements making up the EM603 thermal energy meter are shown below (unit of measurement mm):

ELECTRONIC BOX: DN150 → DN300

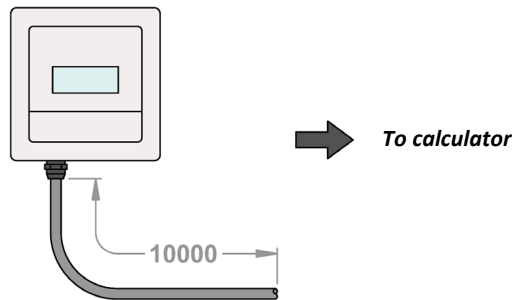

DIRECT IMMERSION TEMPERATURE PROBE

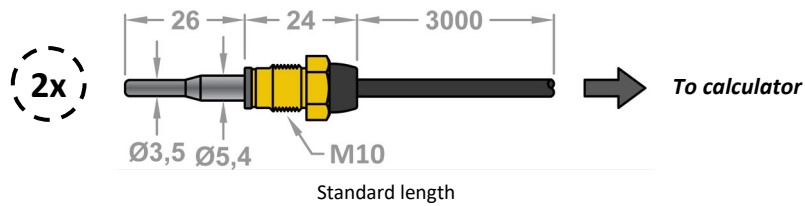

POCKET TEMPERATURE PROBE

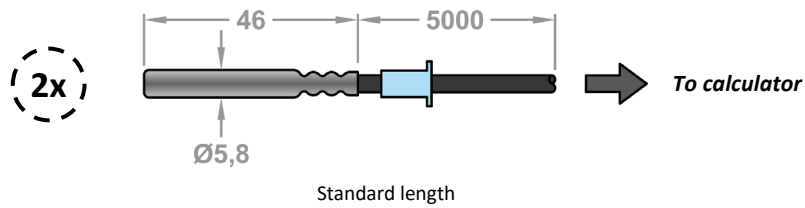

POCKET HOUSING

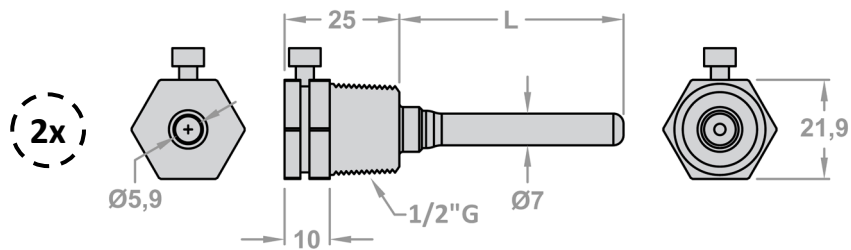

Sizes 1,5÷25 m ³ /h	Sizes 40÷100 m ³ /h	Sizes 250÷1000 m ³ /h
L → 50	L → 75	L → 125

SUPPORT FOR WALL MOUNTING

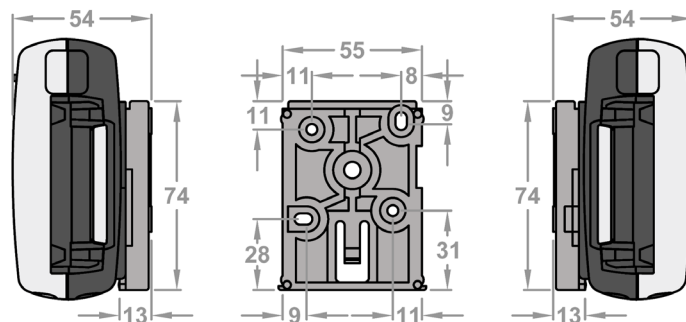

MATERIALS

The materials of the different elements making up the EM603 thermal energy meter are shown below:

CALCULATOR

- Front shell Polycarbonate filled with 10% glass fiber (PC 10% GF) with thermoplastic elastomers (TPE)
- Rear shell Polycarbonate filled with 10% glass fiber (PC 10% GF) with thermoplastic elastomers (TPE)

CABLES

- Flow sensor - Calculator Silicon cable 3 x 0,25 mm² (up to DN125) or 3 x 0,5 mm² (from DN150)
- Temperature probes Silicon cable 2 x 0,22 mm²

SUPPORTS FOR MOUNTING

- Wall support Polycarbonate filled with 20% glass fiber (PC 20% GF)
- Spacer support Polyphenylene sulfide filled with 40% glass fiber (PPS 40% GF)

TEMPERATURE PROBES

- Immersion type Stainless steel W. nr. 1-4404
- Pocket type Stainless steel W. nr. 1-4404

FLOW SENSOR: 3/4" → 2"

- Flow sensor casing Antidezincification brass CW602N
- Transducer Stainless steel W. nr. 1-4404
- O-rings EPDM
- Measuring tube Polyethersulfone (PES)
- Reflectors Stainless steel W. nr. 1-4436 or 1-4350
- Reflectors base Polyethersulfone filled with 30% glass fiber (PES 30% GF)
- Protection cover Polycarbonate filled with 10% glass fiber (PC 10% GF)

FLOW SENSOR: DN50 → DN125

- Flow sensor casing Stainless steel W. nr. 1-4308
- Transducer Stainless steel W. nr. 1-4404
- O-rings EPDM
- Measuring tube Polyethersulfone filled with 30% glass fiber (PES 30% GF)
- Reflectors Stainless steel W. nr. 1-4436 or 1-4350
- Reflectors base Stainless steel W. nr. 1-4436 or 1-4350
- Protection cover Polycarbonate filled with 10% glass fiber (PC 10% GF)

ELECTRONIC BOX: 3/4" → DN125

- External shell Polyamide (PA)
- Internal shell Polyolefin (PO)

FLOW SENSOR: DN150 → DN300

- Flow sensor casing Stainless steel W. nr. 1.4301
- Transducer Titanium
- Transducer base Stainless steel W. nr. 1.4308
- Gaskets Fiber

ELECTRONIC BOX: DN150 → DN300

- Front shell Polycarbonate filled with 10% glass fiber (PC 10% GF)
- Rear shell Polycarbonate filled with 10% glass fiber (PC 10% GF)

OPERATING CONDITIONS

The EM603 thermal energy meter is suitable for indoors installation without the possibility of condensation forming. Outdoor installation is not permitted. It must be used in closed hydronic systems and is supplied by default for installation on the return pipe. If installation on the supply pipe is necessary, it is possible to change the setting on the meter.

The main characteristics and operating conditions of the device depending on the different sizes available are collected in the following table:

TECHNICAL FEATURES			
Size	¾" → DN125	DN150 → DN250	DN300
IP protection (calculator)	IP65	IP65	IP65
IP protection (flow sensor)	IP68	IP67	IP68
Type of medium	Acqua	Acqua	Acqua
Nominal pressure (flow sensor)	25 bar	25 bar	16 bar
Room temperature range	5÷55 °C	5÷55 °C	5÷55 °C
Medium temperature range	2÷130 °C	2÷150 °C	2÷150 °C
Storage temperature range	-25÷60 °C	-25÷60 °C	-25÷60 °C
Calculator mounting	On the wall	On the wall	On the wall

APPROVALS

The different directives and regulations according to which the EM603 thermal energy meter is certified, with the related certificates where present, are shown below:

CERTIFICATIONS

- MID directive (Measurement Instruments Directive 2014/23/EU) → Certificate DK-0200-MI004-040
- DK-BEK 1178 regulation (Danish cooling regulation) → Certificate TS 27.02.012

Heating (MID)		Cooling (DK-BEK 1178)	
Temperature range θ	Differential range $\Delta\theta$	Temperature range θ	Differential range $\Delta\theta$
2 °C...180 °C	3 K...178 K	2 °C...180 °C	3 K...178 K
<i>Mechanical environment: class M1 and M2 – Electromagnetic environment: class E1 and E2</i>			

EUROPEAN DIRECTIVES AND REGULATIONS

- MID directive (Measurement Instruments Directive 2014/23/EU)
- EMCD directive (ElectroMagnetic Compatibility Directive)
- LVD directive (Low Voltage Directive)
- RED directive (Radio Equipment Directive)
- PED directive (Pressure Equipment Directive)
- RoHS directive (Restriction of Hazardous Substances)
- EN 1434:2007/AC:2007 regulation
- EN 1434:2015 + A1:2018 regulation
- EN 1434:2022 regulation

CALCULATOR DATA

The calculator of the EM603 thermal energy meter is equipped with a 7-digit LCD display through which it is possible to view the different recordings made by the device and the settings with which it is configured. Navigation between the different menus and modification of the related parameters can be achieved through the use of the three central buttons.

The main characteristics of the calculator of the EM603 thermal energy meter are collected in the following table:

TECHNICAL FEATURES	
Type of display	LCD with 7 or 8 digits
Display resolution	Depending on the data, up to a maximum of 4 decimal digits
Energy measurement units	Can be set between MWh, kWh, GJ or Gcal
Type of memory	EEPROM (data stored are never lost)
Data logging frequency*	Yearly, monthly, daily, hourly, minute 1 (15'), minute 2 (1')
Data logging depth**	20 year, 36 months, 460 days, 72 hours, 1440 minutes, 360 minutes
Daylight saving time (DST)	Programmable
Clock accuracy (without external adjustment)	Less than 15 min/year
Clock accuracy (with external adjustment)	Less than 7 sec from daylight saving time
Data communication	Through optical head and communication module/s
Length of connection cable to flow sensor	10 m (can be shortened)
Length of connection cable to the temperature probes	From 1,5 to 10 m (depending on the type of probe)

*In the case of yearly and monthly frequencies, the yearly and monthly date on which the EM403 thermal energy meter records the parameter can be directly set by the end user. **The logging depth, namely the number of years, months, days, hours or minutes for which it is possible to navigate within the device's memory, varies according to the logging frequency considered and increases as this latter decreases.

MOUNTING OF THE CALCULATOR

The calculator of the EM603 thermal energy meter can be mounted only on the wall, thanks to the dedicated support included with the product. In this case it is necessary to consider the maximum length of the connection cable between the electronic box and the calculator which is 10 m. Based on the needs, this cable can be shortened on site directly by the installer.

INSTALLING POSITION

In order to guarantee correct functioning, it is necessary to take into account some installation constraints regarding the positioning of the device within the system such as:

1. Do not place the flow sensor at the highest point of the pipe (Fig.1);
2. Do not place the flow sensor immediately after a butterfly valve or a regulating control valve. However, previous installation is permitted (Fig.2);
3. Do not place the flow sensor immediately before or after a circulation pump (Fig.3);
4. Do not place the flow sensor immediately after a double curve oriented on two different planes (Fig.4);

For cases 2, 3 and 4, if you want to proceed with the installation, provide a straight section of pipe between the two elements with a minimum length equal to ten times the nominal diameter of the device. For any other cases not listed, straight pipe sections are not necessary either before or after the installation point.

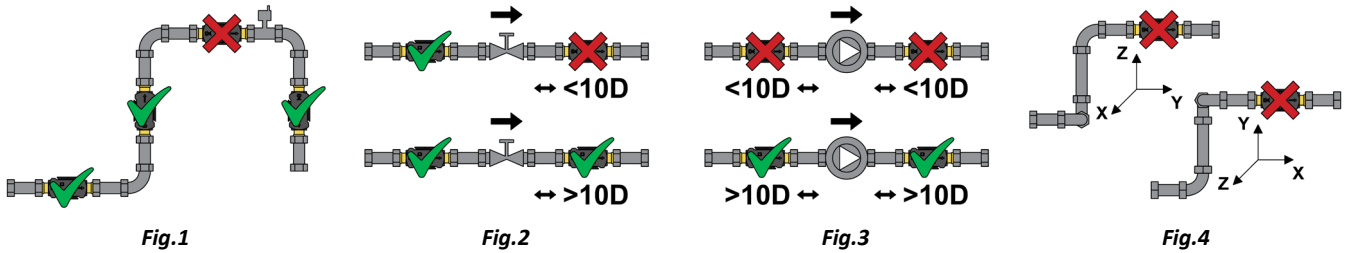

MOUNTING OF THE FLOW SENSOR

The mounting of the flow sensor of the EM603 thermal energy meter must be carried out in accordance with the following two conditions:

1. The direction of flow must agree with the direction of the arrows shown on the device's body;
2. The installation position inside the circuit must agree with the one set on the calculator (supply or return).

 The EM603 thermal energy meter is equipped with an advanced integrated diagnostic system. If the installation direction is not consistent with the set flow direction, the meter generates a specific alarm message.

FLOW SENSOR ORIENTATION: 3/4" → DN125

For models with nominal flow rate between 1,5 and 100 m³/h, the flow sensor can be oriented in any position: horizontal, vertical or inclined (Fig.5). In particular, if the installation is vertical, compatibly with the available space, the flow sensor can be rotated 360° around its axis. If the installation is of the horizontal type, however, the orientation that can be achieved varies depending on the size considered:

- **Models with nominal flow rate up to 2,5 m³/h:** the flow sensor can be oriented with inclinations between 0° and -90°. In particular, orientation with an angle between -45° and -90° is permitted if the absence of impurities and dirt inside the heat transfer fluid has been verified (Fig.6);
- **Models with nominal flow rate from 3,5 to 100 m³/h:** the flow sensor can be oriented with inclinations between 45° and -90°. In particular, orientation with an angle between -45° and -90° is permitted if the absence of impurities and dirt inside the heat transfer fluid has been verified. Orientation with an angle between 45° and 0° is permitted if the absence of air inside the heat transfer fluid has been verified (Fig.7).

What has been analyzed so far is to be applied in the case of heating systems. In the case of cooling or mixed applications, it is recommended to orient the flow sensor with an angle equal to 0°, for models with a nominal flow rate of up to 2,5 m³/h, and with an angle equal to 45°, for models with nominal flow rate from 3,5 to 100 m³/h (Fig.8).

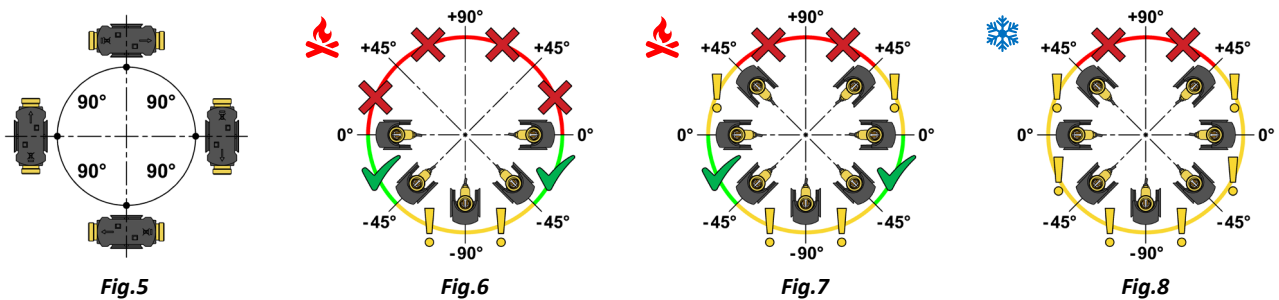

POSITIONING OF THE ELECTRONIC BOX: ¾" → DN125

Thanks to its lightweight, for the models with nominal flow rate between 1,5 and 100 m³/h, the electronic box can be left hanging from the cable, without the need of any support elements (Fig.9). Direct installation on the flow sensor (Fig.10) rather than on the pipes (Fig.11) is not permitted. Since the casing is die-cast, it is waterproof and must not be tampered with. In case of particularly humid environmental conditions, it is recommended to install the box on the wall with the cables hanging freely downwards (Fig.12).

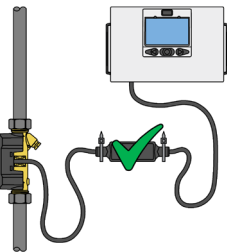

Fig.9

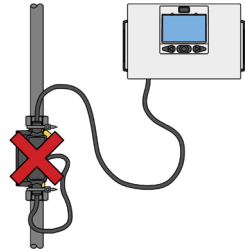

Fig.10

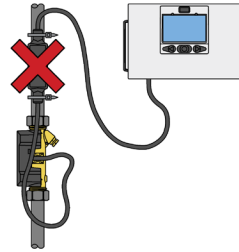

Fig.11

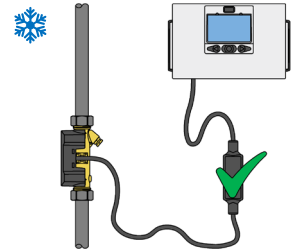

Fig.12

FLOW SENSOR ORIENTATION: DN150 → DN300

For models with nominal flow rate between 250 and 1000 m³/h, the flow sensor can be oriented in any position: horizontal, vertical or inclined (Fig.13). In particular, if the installation is vertical, compatibly with the available space, the flow sensor can be rotated 360° around its axis. If the installation is of the horizontal type, however, the orientation that can be achieved varies depending on the type of application:

- **Heating applications:** the flow sensor can be oriented with inclinations between +90° and -90° (Fig.14);
- **Cooling or mixed applications:** the flow sensor can be oriented with inclinations between 0° and +90° (Fig.15).

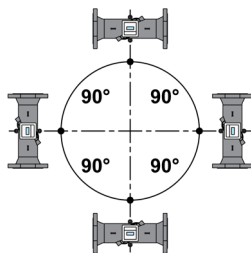

Fig.13

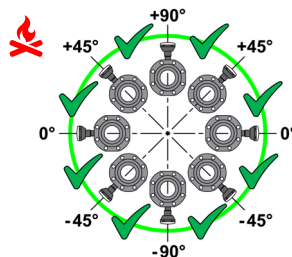

Fig.14

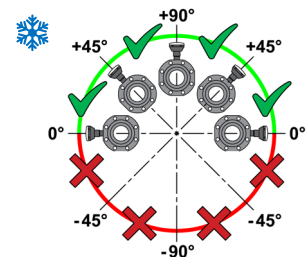

Fig.15

POSITIONING OF THE ELECTRONIC BOX: ¾" → DN125

Due to its robustness, for models with nominal flow rate between 250 and 1000 m³/h, the electronic is fixed to the flow sensor and cannot be removed. To align the reading, it can be rotated up to 270° around its axis. This is done by loosening the second screw on the cylindrical support of the electronic box.

TEMPERATURE PROBES

The EM603 thermal energy meter is equipped with two PT500 temperature probes, one for the supply (T1 probe) and one for the return (T2 probe). As standard, models with nominal flow rate up to 6 m³/h are equipped with direct immersion type probes (L = 3 m) while models with nominal flow rate from 10 m³/h and above are equipped with pocket type probes (L = 5 m). On demand, further combinations can be selected, as per the following table:

Size [m ³ /h]		1,5	2,5	3,5	6	10	15	25	40	60	100	250	400	600	1000
Direct immersion probes	L = 1,5 m	O.D.	O.D.	O.D.	O.D.										
	L = 3 m	S.	S.	S.	S.										
Pocket probes	L = 1,5 m	O.D.	O.D.	O.D.	O.D.	O.D.	O.D.	O.D.	O.D.	O.D.	O.D.	O.D.	O.D.	O.D.	O.D.
	L = 3 m	O.D.	O.D.	O.D.	O.D.	O.D.	O.D.	O.D.	O.D.	O.D.	O.D.	O.D.	O.D.	O.D.	O.D.
	L = 5 m	O.D.	O.D.	O.D.	O.D.	S.	S.	S.	S.	S.	S.	S.	S.	S.	S.
	L = 10 m	O.D.	O.D.	O.D.	O.D.	O.D.	O.D.	O.D.	O.D.	O.D.	O.D.	O.D.	O.D.	O.D.	O.D.

S. = Standard - O.D. = On demand

Devices equipped with direct immersion probes have got the T2 probe directly inserted into the flow sensor while the T1 probe is loose and must be installed in a dedicated probe holder (Fig.16). Hydraulic sealing is provided by compression of the end gasket (the probe does not need to be fully tightened against the stop). Devices equipped with pocket probes instead have got both sensors loose. In this case the installation must be done by inserting the probes into the dedicated pockets included with the device. These pockets in turn must be installed on the pipelines thanks to the help of dedicated fittings (Fig.17). In the case of heating applications, the probe can be oriented in any position: horizontal, vertical or inclined (Fig.18). In the case of cooling or mixed applications, however, orienting the probe with an angle between 0° and -90° is recommended (Fig.19). Installation at angles greater than 0° requires the probe to be suitably thermally insulated.

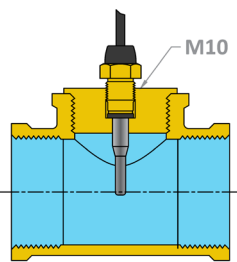

Fig.16

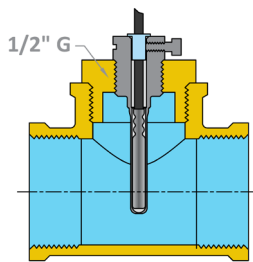

Fig.17

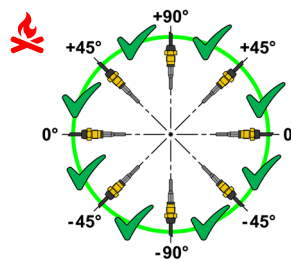

Fig.18

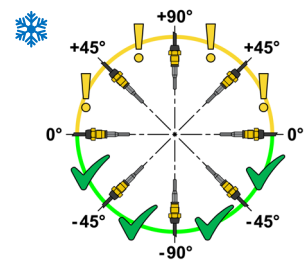
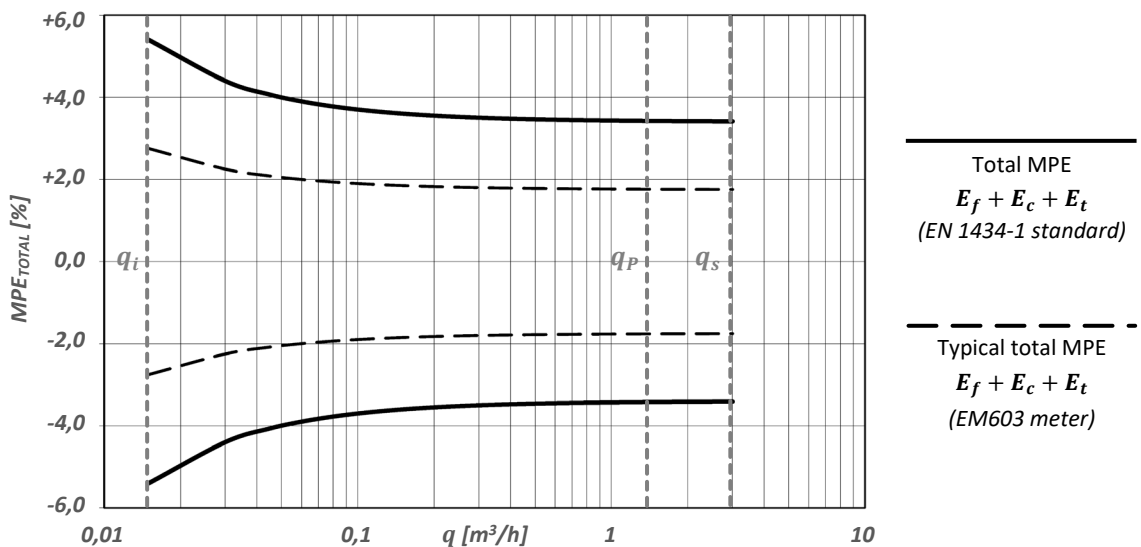

Fig.19

MEASURING ACCURACY

The measurement accuracy of the EM603 thermal energy meter complies with the minimum requirements indicated in the EN 1434-1 standard. As an example, consider the graph below which represents the typical measurement accuracy (MPE) of the EM603 thermal energy meter ($q_p = 1,5 \text{ m}^3/\text{h}$, $\Delta\theta = 30 \text{ K}$) compared to the limits imposed by EN 1343-1 standard.



PRESSURE DROP DIAGRAM

The flow coefficients of the different meter sizes available are shown below:

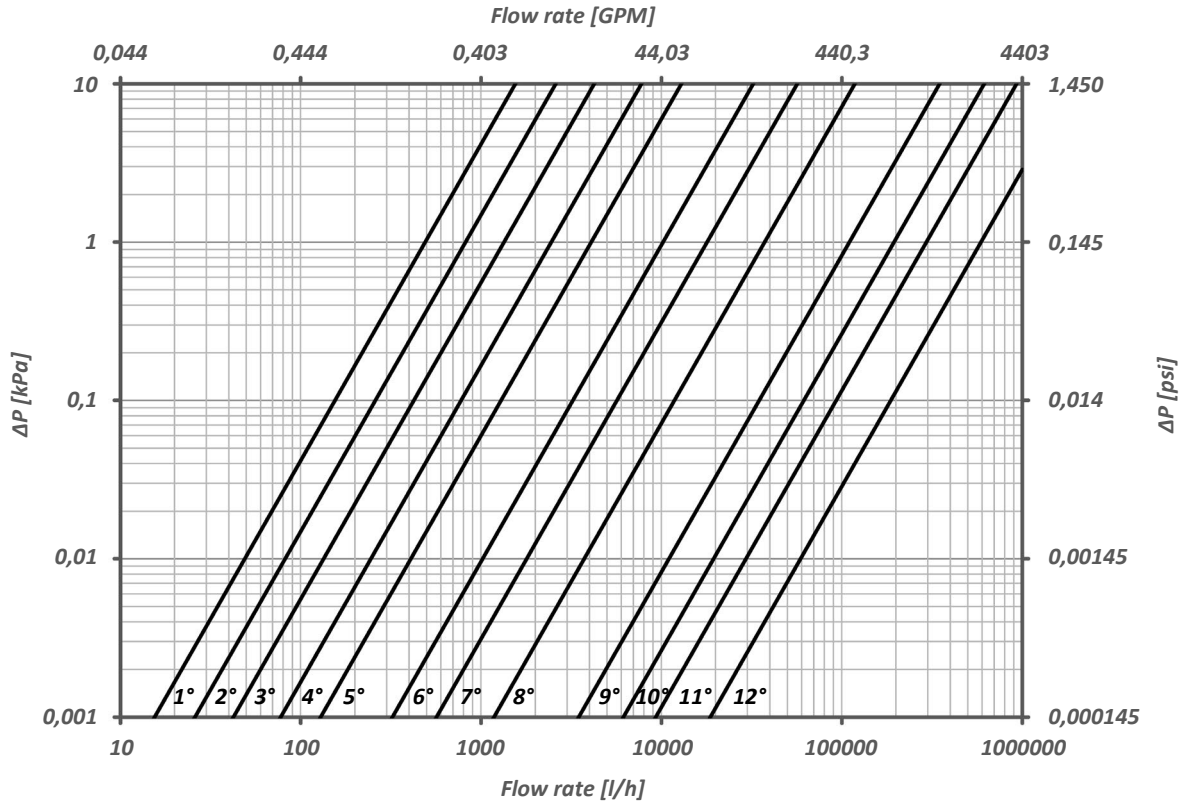

Size [m³/h]	1,5	2,5	3,5	6	10	15	25	40	60	100	250	400	600	1000
Kv	4,9	8,2	13,4	24,5	40	40	102	179	373	373	1100	1945	2940	5900
Cv	5,7	9,5	15,5	28,3	47,2	47,2	118	207	431	431	1272	2248	3399	6820
PN	25	25	25	25	25	25	25	25	25	25	25	25	25	16
Curve	1°	2°	3°	4°	5°	5°	6°	7°	8°	8°	9°	10°	11°	12°

FLOW RATE MEASUREMENT

The flow sensor inside the EM603 thermal energy meter is of the ultrasonic type. Thanks to the absence of moving parts, this technology minimizes the need for maintenance of the device, thus maximizing its reliability and measurement precision over time.

COMMUNICATION PROTOCOL

The EM603 thermal energy meter has an optical interface on the front body that can be used for local reading of the device using an appropriate optical probe. At the same time, based on communication needs, the device can be equipped with one or two different communication protocols. The different communication protocols with which the EM603 thermal energy meter can be supplied are collected in the following table:

Protocol*	Communication standard	Transmission speed / Transmission frequency
<i>M-Bus</i>	EN13757:2013	300, 2400, 9600 e 19200 baud (automatic detection)
<i>M-Bus Wireless</i>	EN13757:2019	912,5/915/918,5 MHz
<i>Modbus RTU**</i>	MODBUS RTU RS-485	300, 2400, 9600, 19200, 38400, 57600, 76800 e 115200 baud
<i>Modbus TCP/IP</i>	MODBUS TCP/IP	10/100 Mbit/s
<i>BACnet® MS/TP</i>	ASHRAE 135.1-2016 e ISO 16484-5	9600, 19200, 38400, 57600, 76800 e 115200 baud (automatic detection)
<i>BACnet® IP</i>	ASHRAE 135.1-2016 e ISO 16484-5	10/100 Mbit/s
<i>LoRaWan</i>	LoRa Alliance®	868 MHz

*Each protocol is also equipped with two pulse inputs for connecting other measuring devices such as drinking water meters (3,6V, max. 5µ A). **Factory settings: *Speed* → 9600 baud, *Parity* → even, *Stop bits* → 1 stop bit. These parameters can be changed by the end user using a specific additional accessory. For further information, contact Pettinaroli technical service directly.

POWER SUPPLY

The EM603 thermal energy meter can be supplied with one of the following power supplies:

- Lithium integrated battery 3,65V DC (lifetime up to 16 years in conditions of T_{BATTERY} < 30°C)
- External power supply module 230V AC;
- External power supply module 24V AC/DC.

Availability of a given type of power supply may vary depending on the type of communication protocol selected, as shown in the following table:

Power supply	<i>M-bus</i>	<i>M-bus Wireless</i>	<i>Modbus RTU</i>	<i>Modbus TCP/IP</i>	<i>BACnet® MS/TP</i>	<i>BACnet® IP</i>	<i>LoRaWan</i>
Battery	✓	✓	NO	NO	NO	NO	✓
230V AC	✓	On request	✓	✓	✓	✓	On request
24V AC/DC	✓	On request	✓	✓	✓	✓	On request



Devices equipped with external power supply are supplied without the connecting cable.

COMPONENTS REPLACEMENT

The EM603 thermal energy meter is modular, meaning that if it is needed to replace one of the internal components of the device, it is not necessary to renew the entire device. The replaceable elements are:

- Power module
- Communication module
- Temperature probes



Regarding the temperature probes, the replacement must be done for both components (T1 probe and T2 probe). Replacement of the single probe is not allowed.

GENERAL NOTES

For further technical and installation information, please refer to the dedicated literature or directly contact Pettinaroli technical support.