



DESCRIPTION

51CRFV

Compression ends heavy duty full-flow ball valve made of corrosion resistant brass (ADZ or DZR). Compression ends comply BS864.2 – EN1254-2 standards.

For copper and soft steel pipes.

Green steel handle.

Conform to **EN13828**.

DIMENSIONS

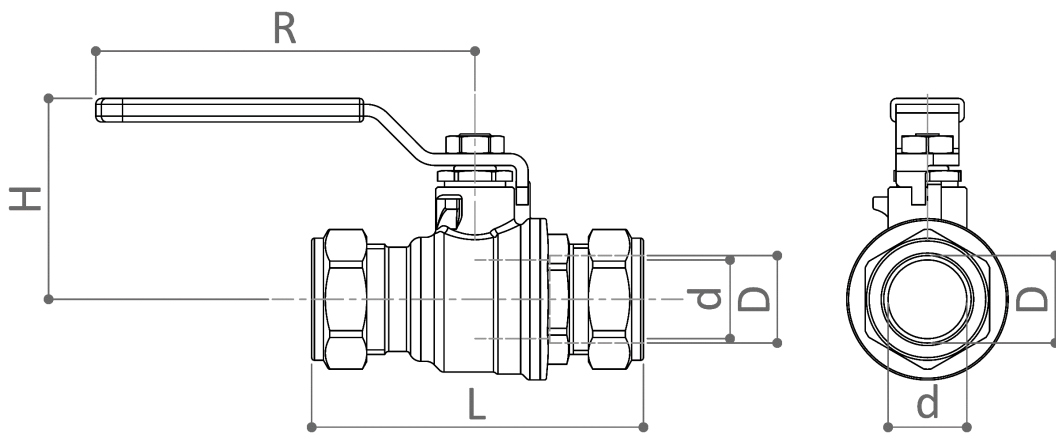

Dimensions in mm

D	d	H	L	R	Weight [g]
12 mm	10	36	65	75	180
15 mm	15	39	74	75	240
18 mm	20	49	84.5	95	380
22 mm	20	49	84.5	95	410
28 mm	25	61	91	120	660
35 mm	32	66	106	120	1000
42 mm	40	82	127	150	1370
54 mm	50	89	149	150	2560

MATERIALS

- Body** CW602N (UNI EN 12167) CuZn39Pb2As T.E.A. plated
- Ball** CW602N (UNI EN 12167) CuZn39Pb2As T.E.A. plated
- Stem** CW602N (UNI EN 12167) CuZn39Pb2As
- Stuffing box** CW614N (UNI EN 12164) CuZn39Pb3 Adjustable
- Compression ends** CW602N (UNI EN 12167) CuZn39Pb2As T.E.A. plated
- Seats** 2 x PTFE on the ball + 1 x PTFE on the stem
- O-rings** 2 x FKM on the stem
- Handle** Delta Protect coated steel. PVC grip with “Pad Printing”

PRESSURE DROP DIAGRAM

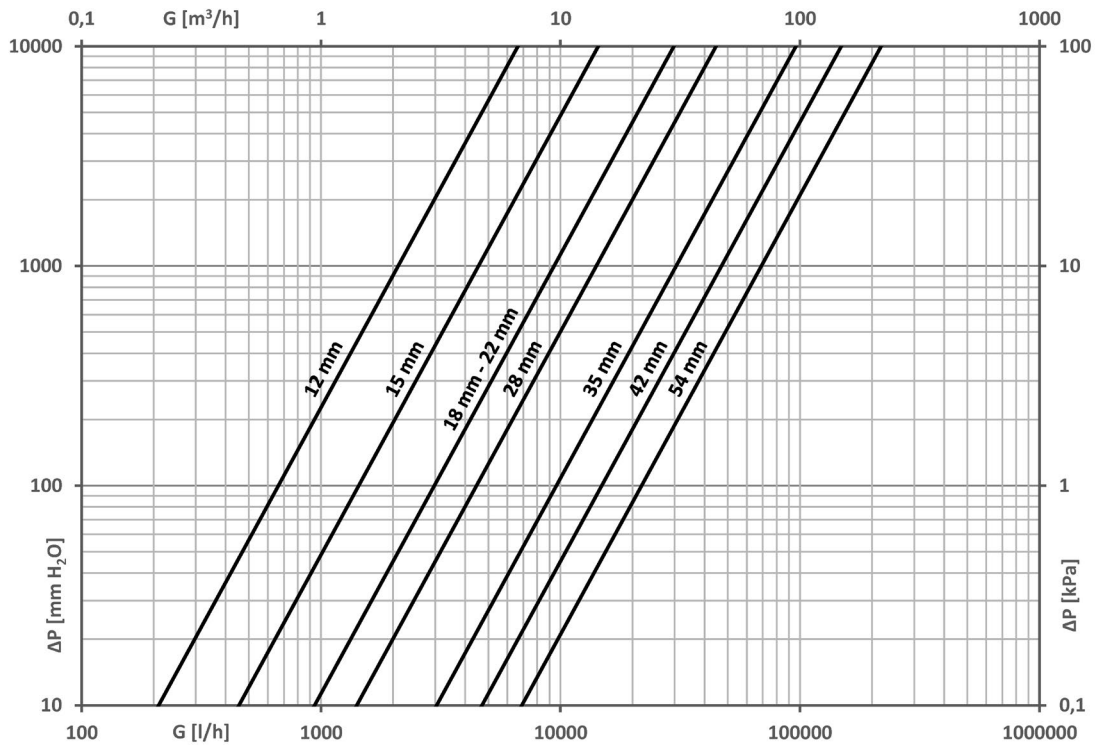

Size	12 mm	15 mm	18 mm	22 mm	28 mm	35 mm	42 mm	54 mm
Kv	6.7	14.5	30	30	45	97	150	220
PN	16	16	16	16	16	16	16	16

RECOMMENDED WORKING TEMPERATURE / PRESSURE LIMITS

16 bar – 30°C – non shock

6 bar – 110°C – non shock

Lower temperature limit with 50% glycol: -20°C. No frost.