



DESCRIPTION

# 52CE/2

M x M end "Extra Compact" full port ball valve with red butterfly lever.

Conform to EN 13828

DIMENSIONS

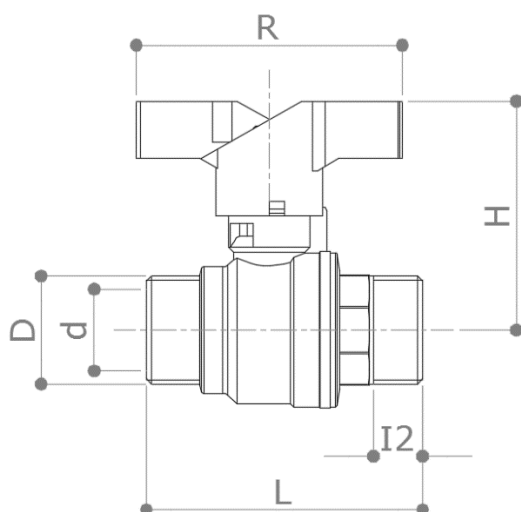

D	½"	¾"	1"
d	15	20	25
H	46	55.5	56
I2	12	13	14
L	56	67.5	76.5
R	58	65	65
Weight [g]	170	285	430

Dimensions in mm

All threads are conform to ISO 228 standard

MATERIALS

- Body** CW617N (EN 12165) CuZn40Pb2 External nickel plated
- Ball** CW617N (EN 12165) CuZn40Pb2 Chromium plated
- Stem** CW614N (EN 12164) CuZn39Pb3
- Stuffing box** CW614N (EN 12164) CuZn39Pb3
- Seat** 2 x PTFE + 1 x PTFE seal on the stem
- O-Rings** 2 x FKM
- Handle** Painted aluminium

APPROVALS



RECOMMENDED WORKING TEMPERATURE/PRESSURE LIMITS

- 28 bar – 100°C – non shock
- 10 bar – 150°C – non shock

PRESSURE DROP DIAGRAM

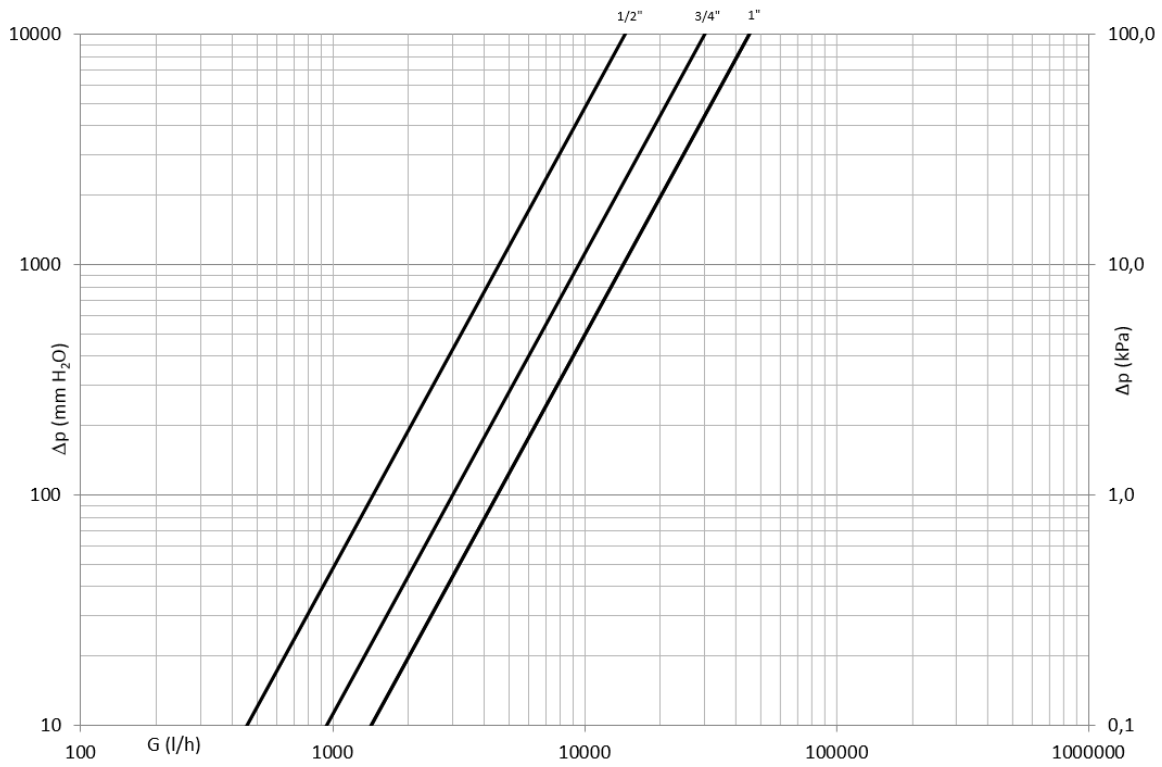

Dim.	1/2"	3/4"	1"
Kv	14.5	30	45
PN	28	28	28

TEMPERATURE / PRESSURE DIAGRAM

