

VORTEX 4

VALVE ASSEMBLIES

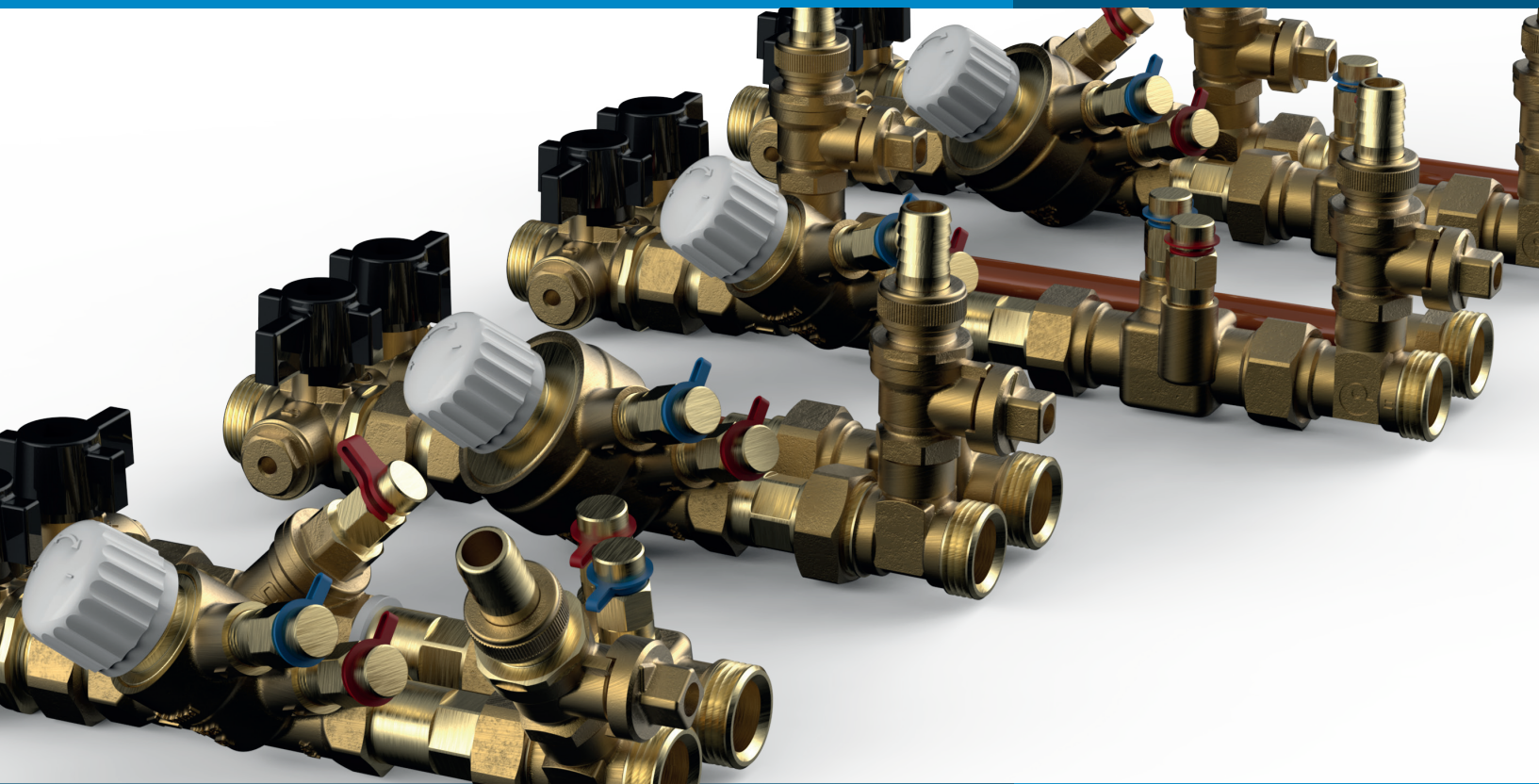

Engineered **terminal unit connection sets** for the **flow limitation and temperature control** of terminal units in heating and chilled water systems



Commissioning kits for terminal units

Pettinaroli's versatile range of **valve assemblies for fan coils, chilled beams and other hydronic terminal units** offers significant **benefits over standard products** - for specifiers, installers, commissioning engineers and building operators/ owners.

The valve assembly is a **modular approach** to meeting the flushing, flow balancing, isolation, and temperature control requirements of each terminal unit.

Pettinaroli's pre-fabricated valve assemblies ensure that **everything required** for a successful connection is **supplied in one package**. Furthermore, off-site assembly and testing **reduces site time and virtually eliminates costly failures**.

Units are available in manual/automatic/pressure independent characterised control valves, offering **different levels of functionality to meet the needs and budgets of each project**, whilst sharing the high quality that is synonymous with the Pettinaroli name.

DESIGNERS & SPECIFIERS

Fewer components for each project.

Flexibility in the type of pipe specified.

Choice of valve location, close coupled with terminal unit, or mounted in pipework.

INSTALLERS

Everything required for a successful connection assembly to a terminal unit is **supplied in one package**.

Fewer components to be ordered for each project.

Each unit can be **tagged and individually identified** to each terminal unit.

The unit may be orientated in the **horizontal or vertical** plane on site.

Euroconus connections allow various pipe types and diameters to be used for the runs connecting terminal units.

COMMISSIONING & MAINTENANCE

All valves required for commissioning of the terminal unit are **in one location**.

Insulation boxes (available on request) can be opened and re-sealed in seconds with no damage to pipe lagging.

Automatic balancing valves reduce commissioning time to flushing and verification.

Pressure independent valves offer **full authority temperature control and maximum flow rate limiting**.

BENEFITS

✓ **CONNECTING KIT FOR TERMINAL UNITS** (fan-coils, chilled beams and air handling units)

✓ **REDUCED ON-SITE LABOUR TIME**

✓ **FACTORY TESTED FOR MINIMUM LEAKAGE RISK**

✓ **MADE IN UK WITH ITALIAN TECHNOLOGY AND ENGINEERING**

✓ **FLEXIBLE AND BESPOKE CONFIGURATIONS** (automatic, manual balancing)

✓ **NO FLUSHING THRU CONTROL VALVE** (100% safe)

FEATURES

- ✓ AVAILABLE IN BG 29 AND COMPACT VARIETIES
- ✓ DIRT RESISTANT PICV AS STANDARD
- ✓ HIGHEST KVS AND LOWEST RESISTANCE FLUSHING BYPASS ON THE UK MARKET AS STANDARD
- ✓ COMPONENTS DESIGN FOR OPTIMAL MAINTENANCE, CHANGEABLE AND REUSABILITY
- ✓ FEATURES A FULL BORE DRAIN TO ENSURE HIGH FLUSHING VELOCITY AS STANDARD
- ✓ ADDITIONAL OPTIONS AVAILABLE (AIR VENT, STRAINERS ETC)

VORTEX 4 Compact

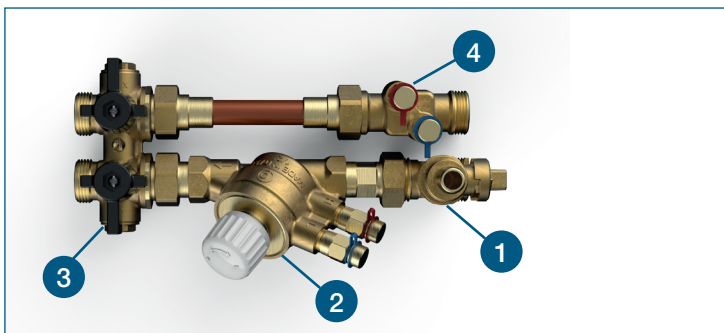

VORTEX 4 29

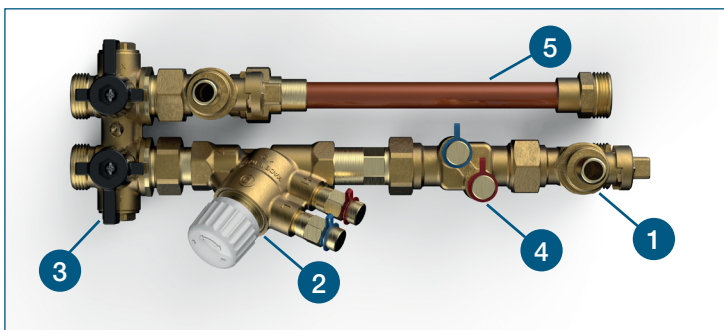

1

Full Bore Drain



2

Dirty resistant PICV



3

High Kvs
Flushing Bypass



4

On site cleanable Venturi
Metering Station



5

Copper pipe with Tee and
Bypass at similar free area
as the pipe diameter

FLUSHING OF MAIN PIPE LINE

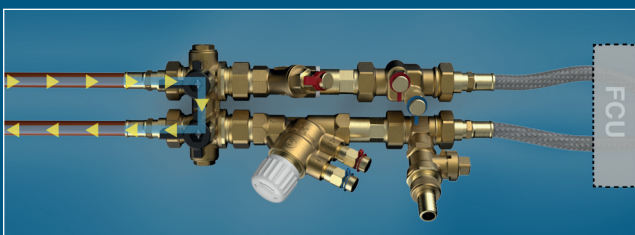

FULL CLOSE

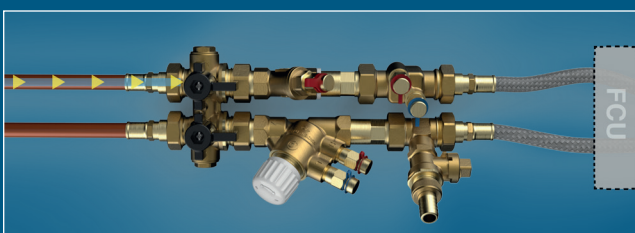

FORWARD FLUSHING

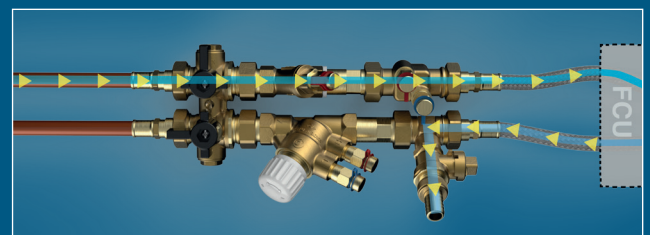

READY FOR COMMISSIONING



VORTEX 4

VORTEX4 RANGE CONFIGURATOR

VORTEX 4 Compact Series

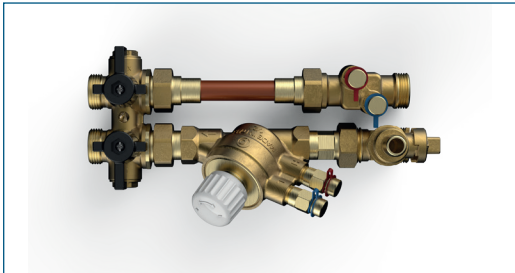
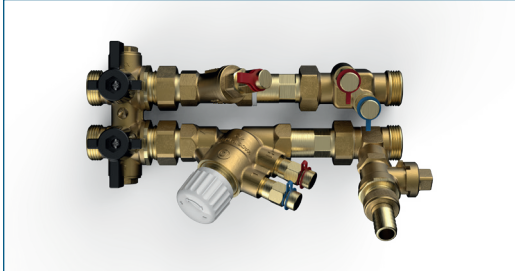

VORTEX 4 29 Series

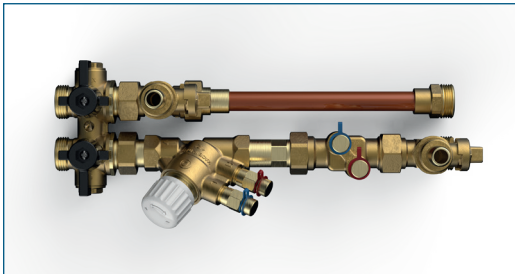
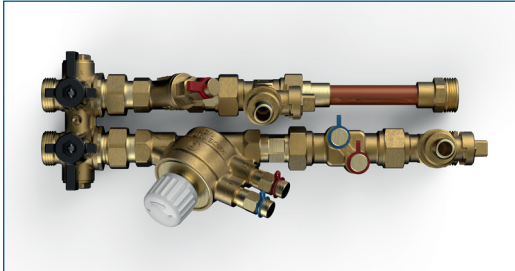

VX4 D1 RCLA 0

VALVE SET OPTIONS

- 0 - Standard
- D - Double drain & Y strainer
- E - Double drain
- G - Added test points, double drain & Y strainer
- I - Added test points, double drain, AAV & Y strainer
- J - Double drain, strainer & AAV
- K - AV & Strainer
- M - Manual air vent
- P - Double drain & additional test point
- Q - Double drain & manual AV
- S - Y strainer

VENTURI SIZE

- 0 - No Venturi
- A - 3 mm
- B - 4.25 mm
- C - 6 mm
- D - 7.5 mm
- E - 9 mm
- F - 10.5 mm

UNIT HANDLING

- L - Left
- R - Right
- H - Horizontal left (Handles upwards)
- K - Horizontal right (Handles upwards)
- M - Horizontal left (Handles downwards)
- N - Horizontal right (Handles downwards)

SERVICE TYPE

- C - Cooling (Blue)
- H - Heating (Red)

VALVE SET CONFIGURATION

- R - PICV in return, TICV on opposite leg
- F - PICV in flow, TICV on opposite leg
- A - PICV in return, TICV after
- B - PICV in return, TICV before

VALVE LINE SIZE AND FLOW TYPE

- 1 - VL.04
- 2 - L.04
- 3 - H.04
- 4 - L.06
- 5 - H.06

VALVE TYPE

- B - 91 PICV
- D - 92 PICV

40 MM VX4 UNIT



Pettinaroli UK

Riverside, Unit K - Austin Way - Hamstead Industrial Estate Birmingham B42 1DU
 Telephone: +44 (0)121 358 2012 - Email: solutions@pettinaroliuk.com
 web: <http://www.pettinaroliuk.com>



FS514077